

Moduł hydrauliczny Aquarea generacji J i H

Widok z boku

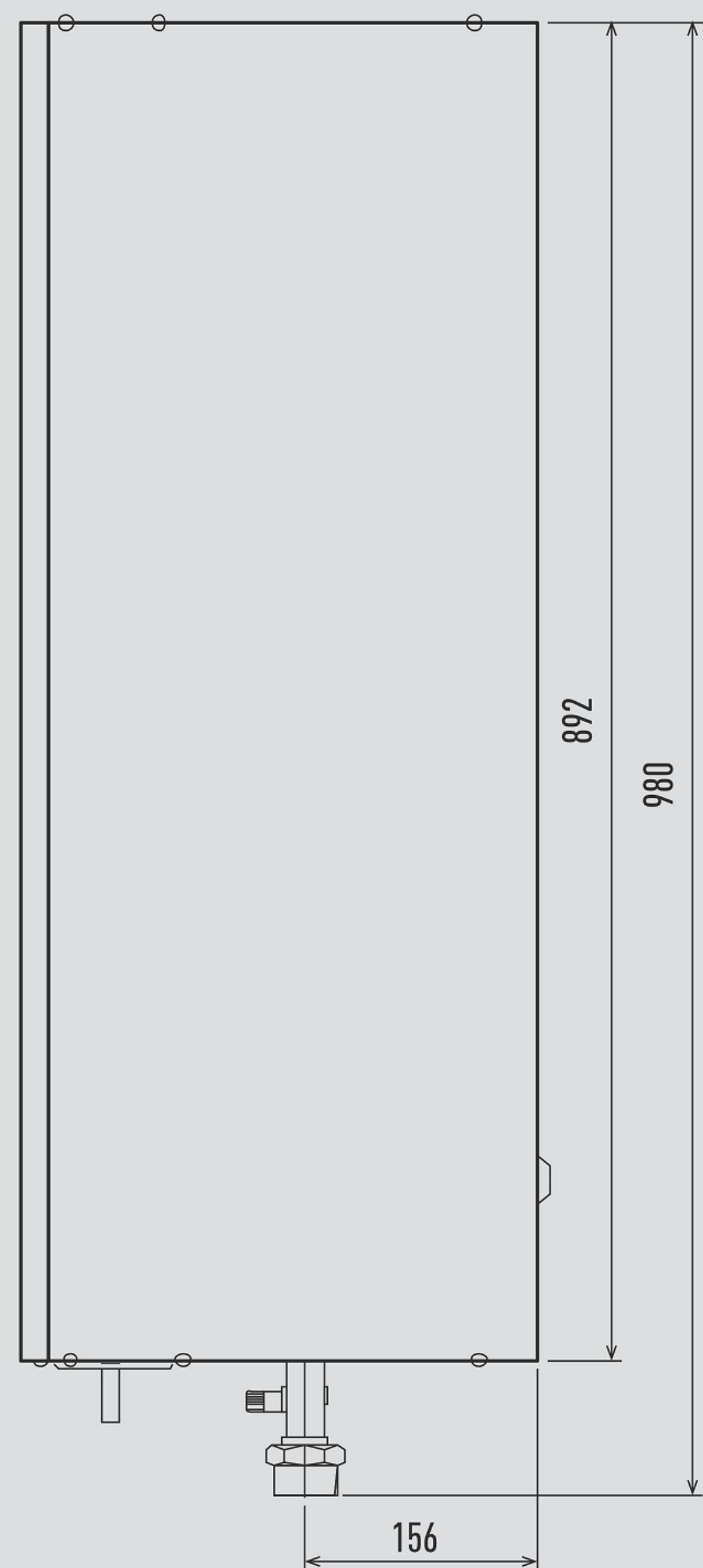

Widok z przodu

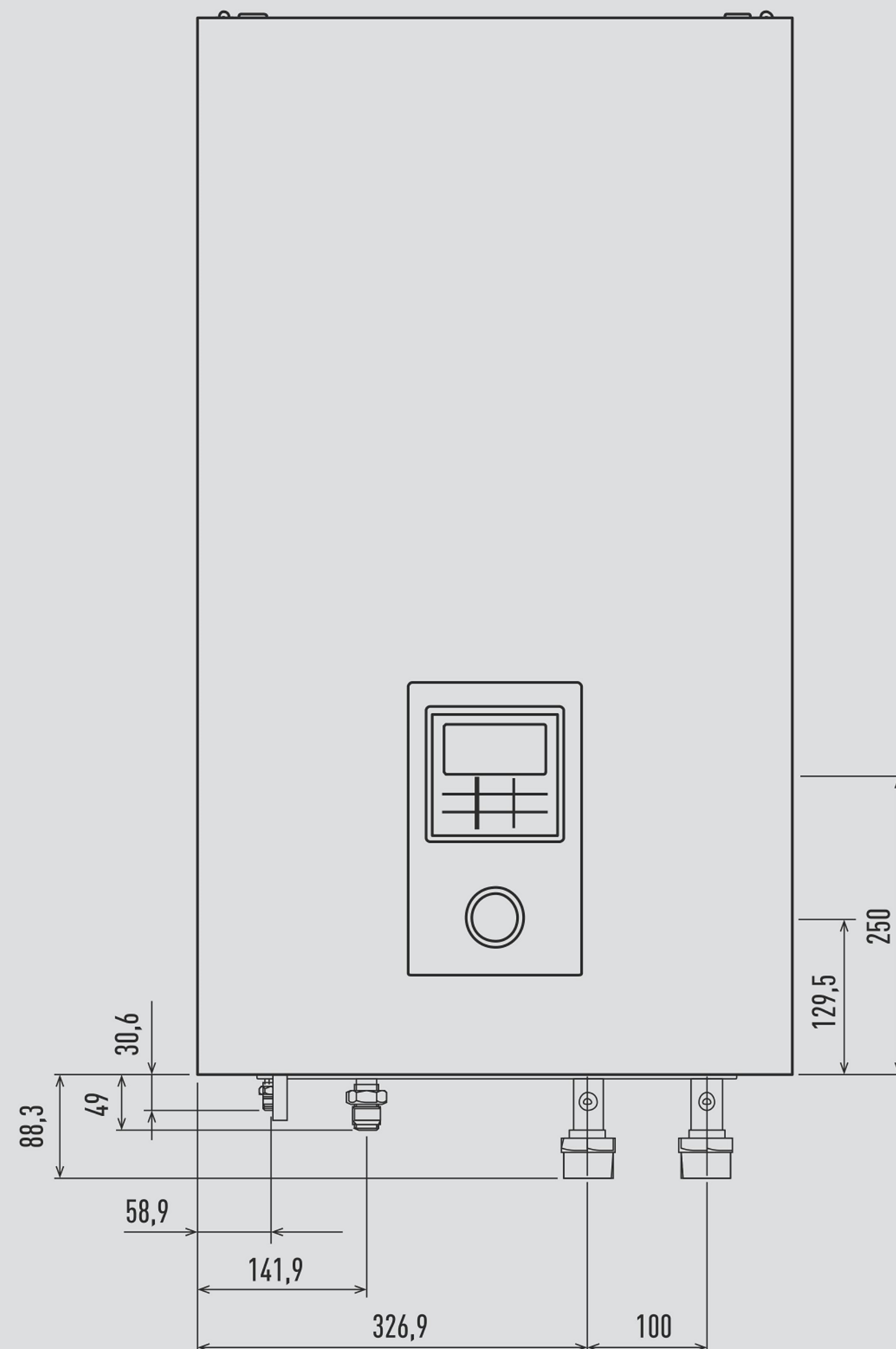

Widok z dołu

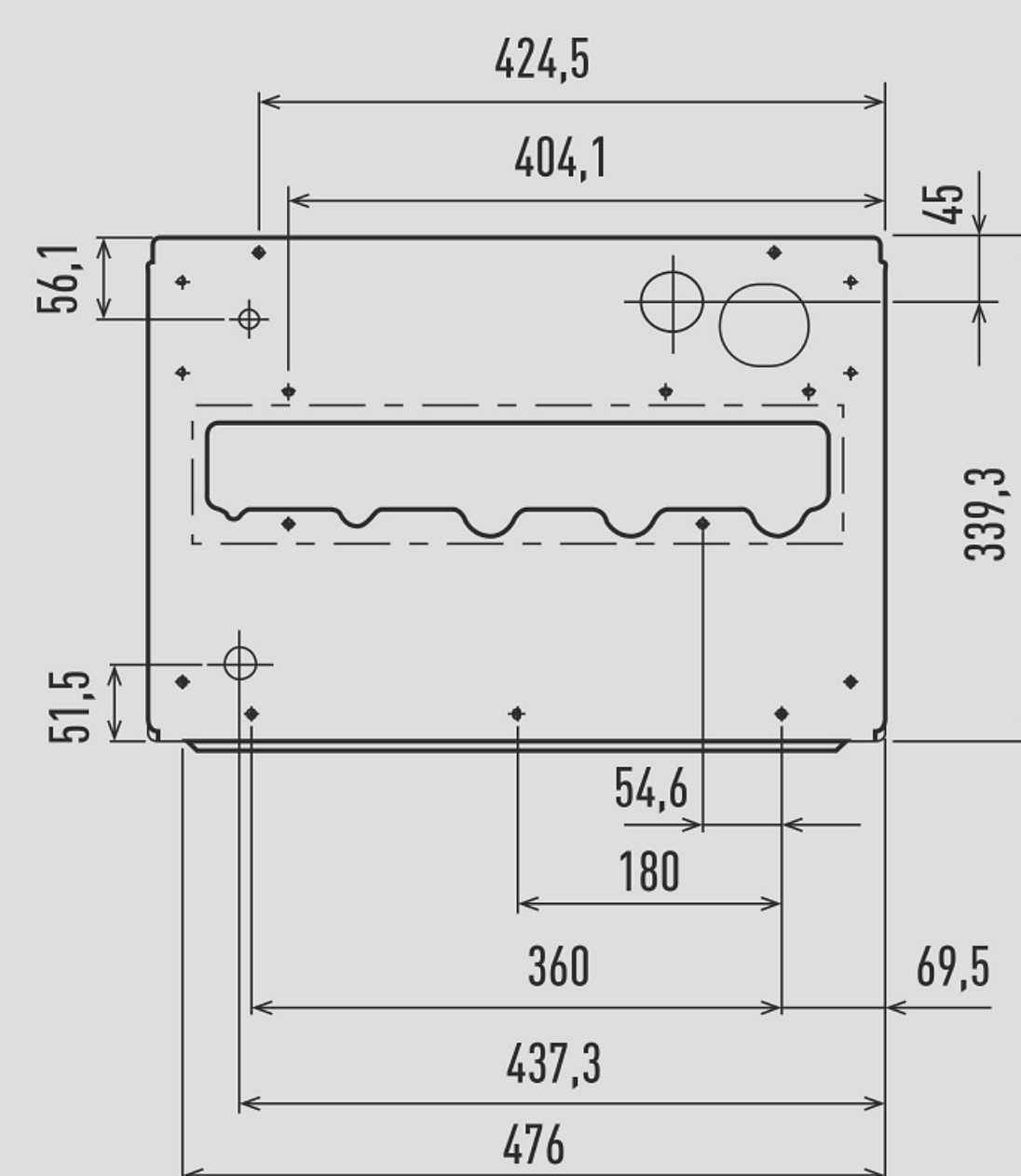

Widok z góry

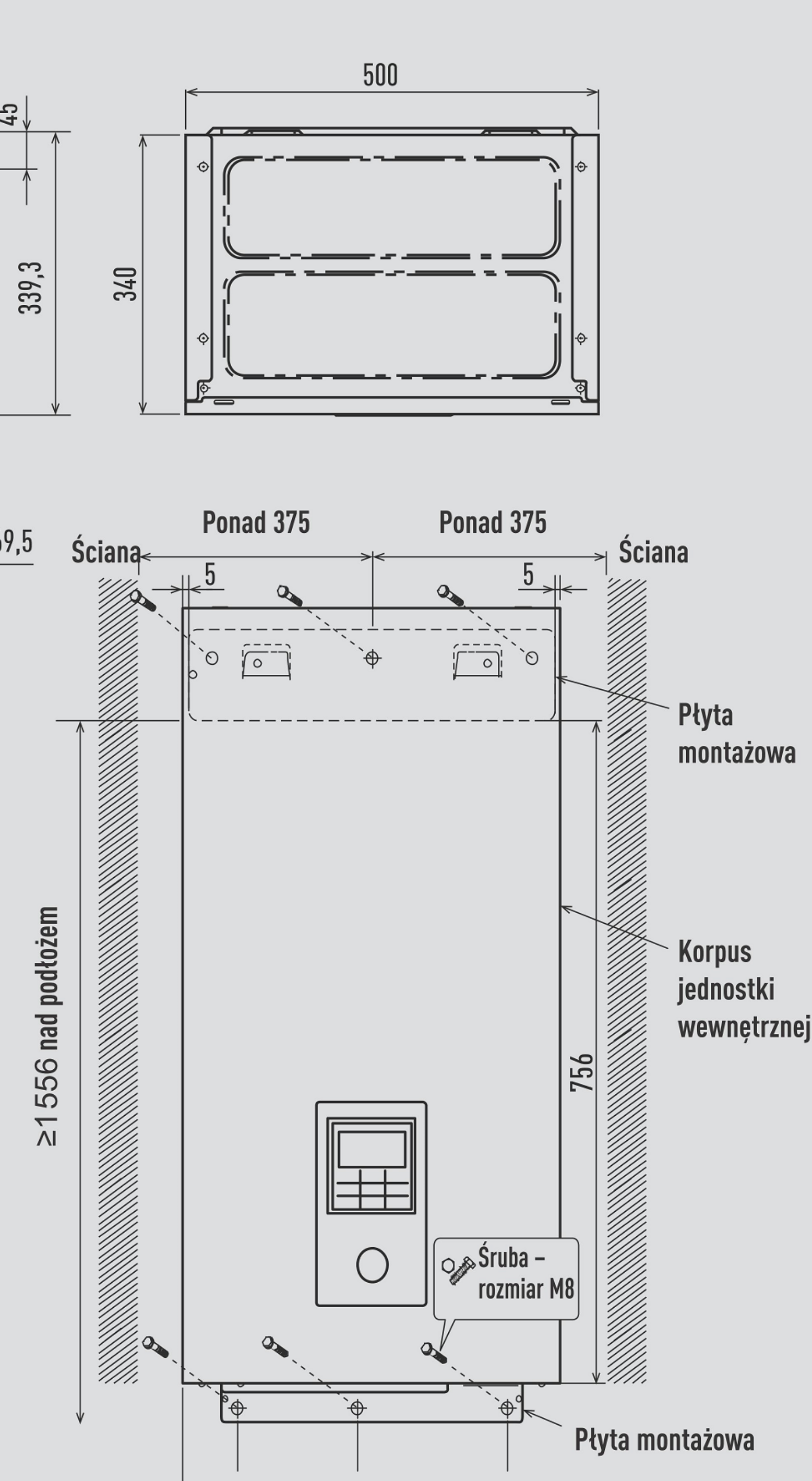

Jednostka zewnętrzna Aquarea High Performance typu split o mocy 3 i 5 kW

Wymagana ilość miejsca do instalacji

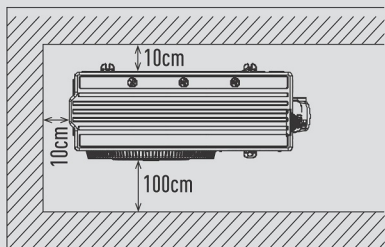

Rozstaw śrub kotwiących 355 x 260

Widok z góry

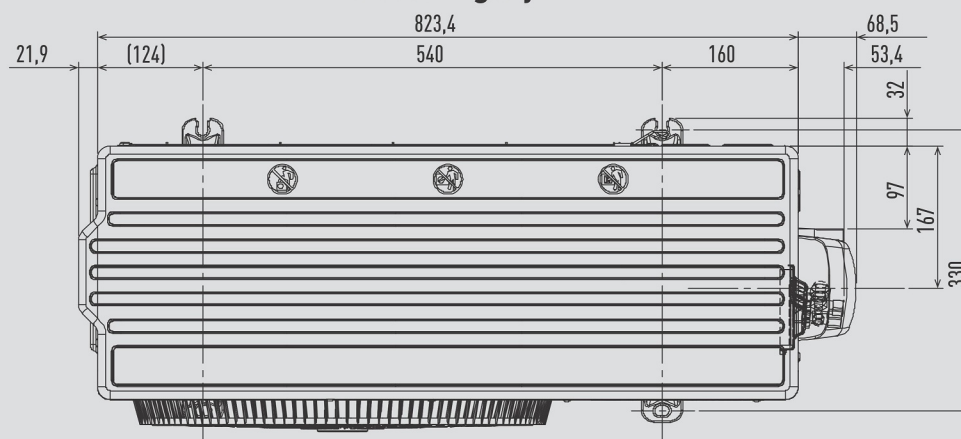

Widok z boku

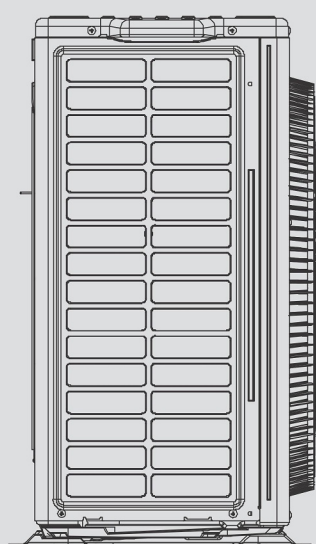

Widok z przodu

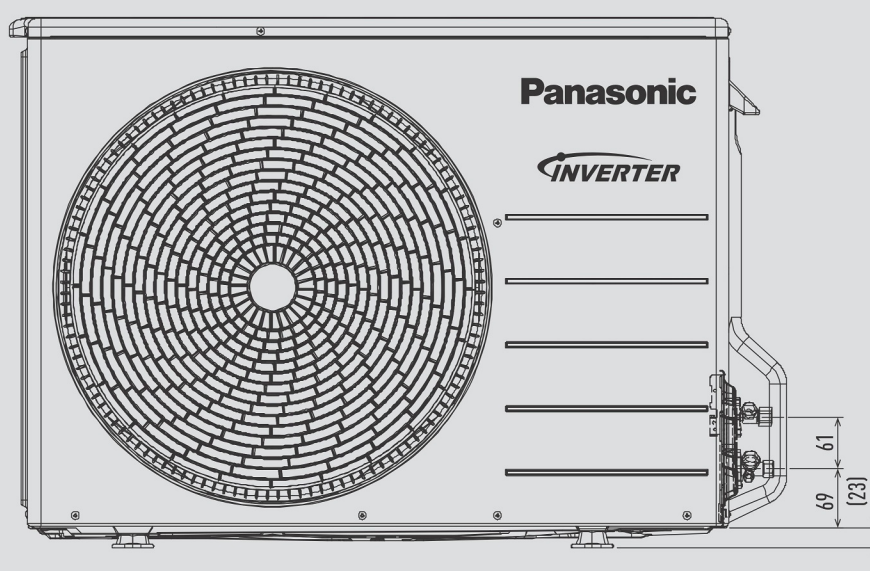

Widok z boku

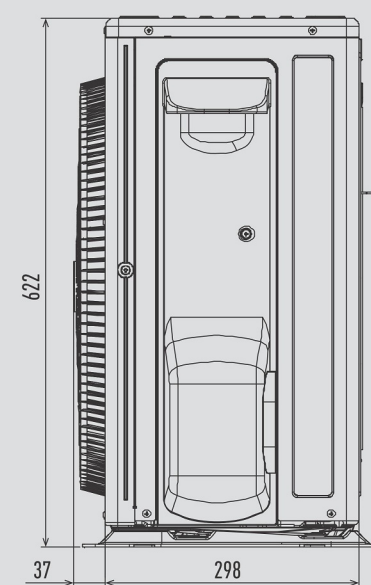

Jednostka: mm

Jednostka zewnętrzna Aquarea High Performance typu split o mocy 7 i 9 kW

Widok z góry

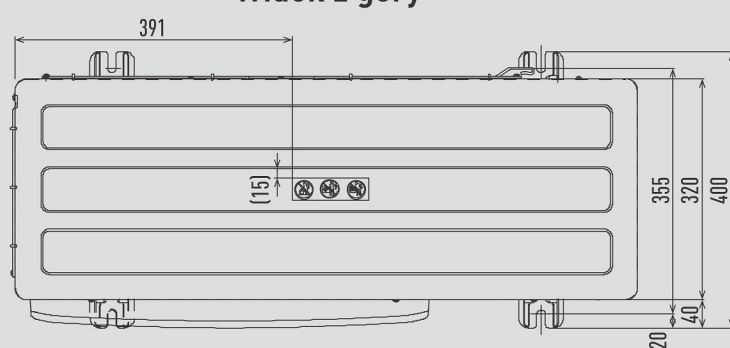

Widok z boku

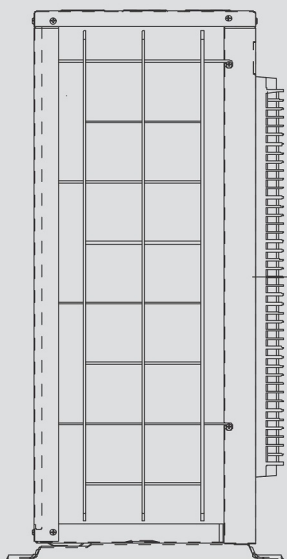

Widok z przodu

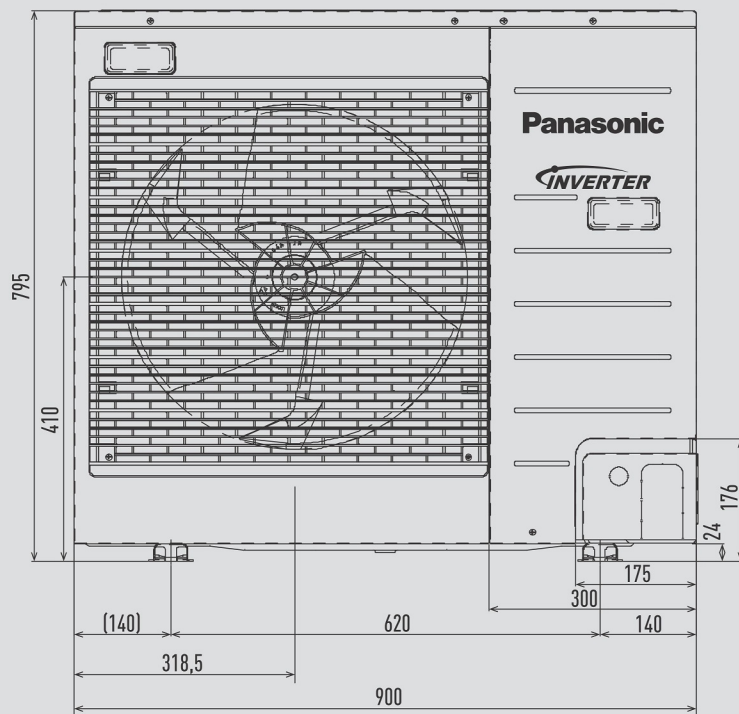

Widok z boku

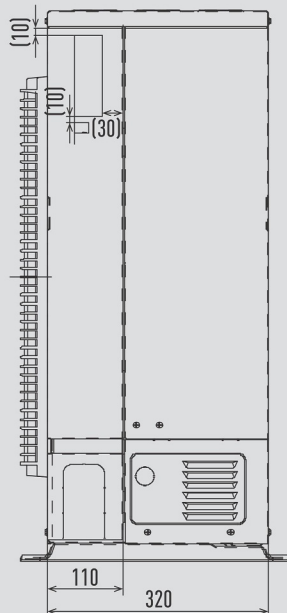

Widok z tyłu

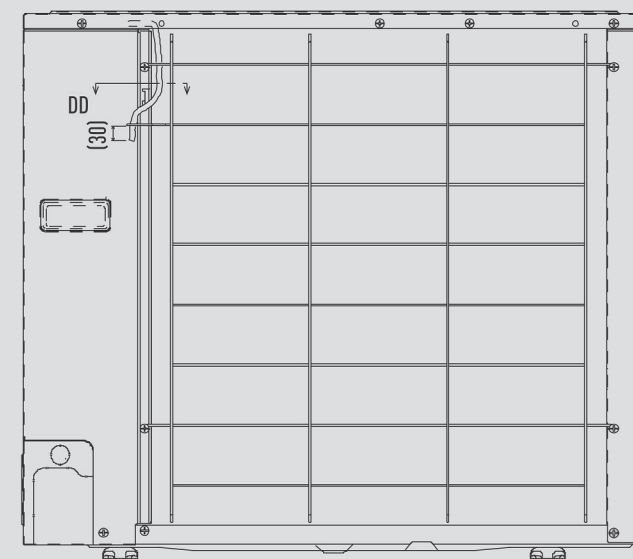

Jednostka: mm